

Item	Description	Material	Specification	Qty
1	Fan Motor		3/4HP x 6P	1 pc
2	Motor Frame Ass'y	H. D. G. S.		1 pc
3	Fan	ABS	770mm	1 set
4	Casing	F. R. P.		2 pcs
5	Hand Hole			1 pc
6	Sprinkler Head	Nylon	050	1 pc
7	Sprinkler Pipe	P. E.		4 pcs
8	Stand Pipe	P. V. C.		1 pc
9	Filling	P. V. C.		1 set
10	Stopper or Column	P. P.		1 set
11	Filling Supportor	H. D. G. S.		1 set
12	Casing Supportor	Nylon		3 pc
13	Inlet Louver	P. V. C.		1 set
14	Water Basin	F. R. P.		1 pc

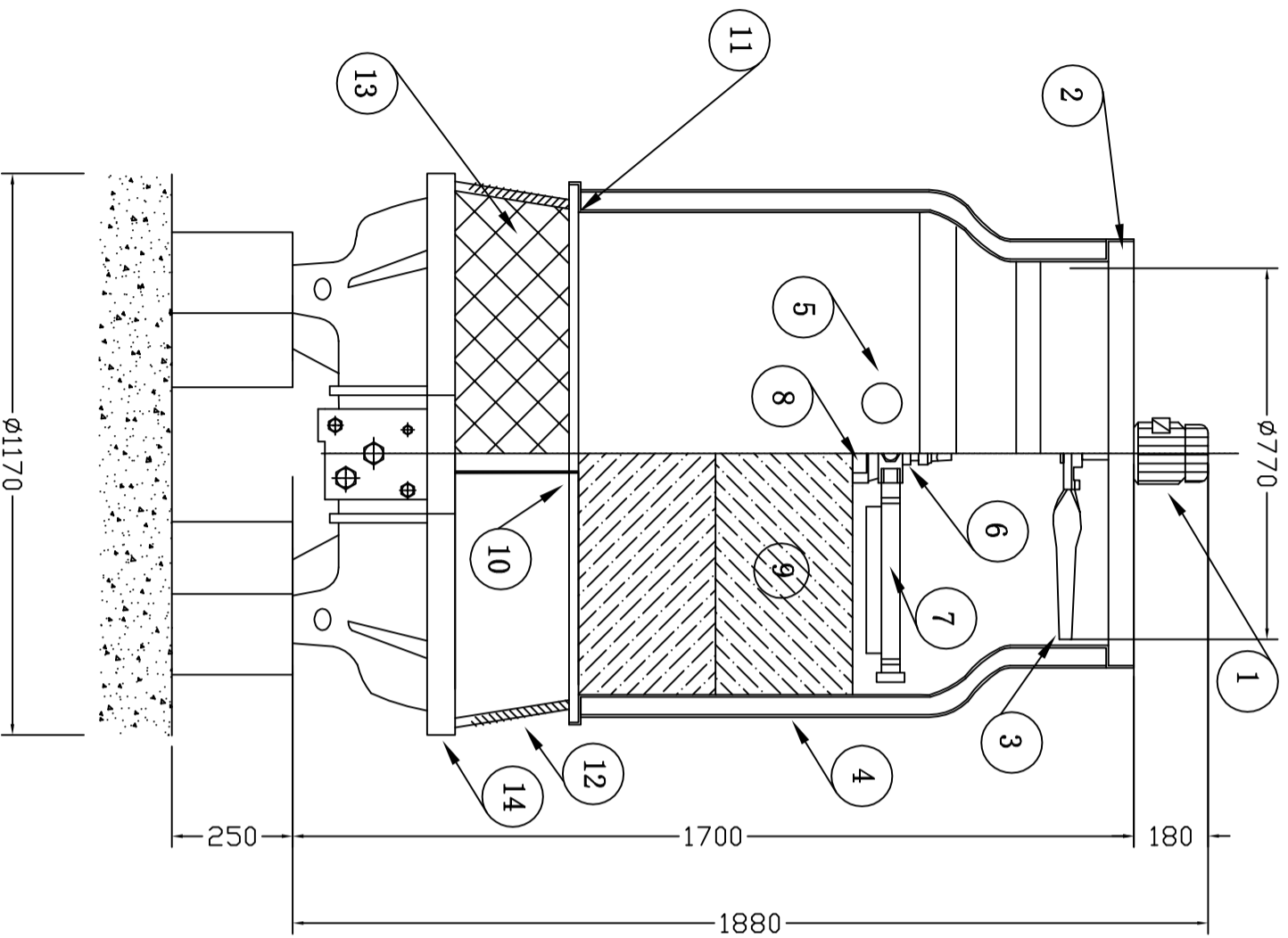

REMARKS H. D. G. S : HOT DIP GALVANIZED STEEL.

Drain	25A ( 1 B)	Over Flow	25A ( 1 B)
Outlet	50A ( 2 B)	Quick Filler	15A (1/2B)
Inlet	50A ( 2 B)	Automatic Filler	15A (1/2B)

Pipe Connections

Dry Weight	80 kgs	Operating Weight	320 kgs
------------	--------	------------------	---------

Loading Data

Ambient Wetbulb	28° C	Air Volume	160 M <sup>3</sup> /MIN
Outlet Water Temp	32° C	Water Flow	260 L/MIN
Inlet Water Temp	37° C	Cooling Load	78000 KCAL/HR

Design Condition

DATE	12.02.20	DWG NO.	ART-20-0L	REV NO.	ART-20-0L-00
MODEL	ART-20	DRAWN BY	ZHAO RH	CHECKED BY	LINDA LIU
DWG TITLE	COOLING TOWER ASS'Y DRAWING	APPROVED BY	SOONG CC		



AMCON (HK) SALES & SERVICE PTE LTD  
(2382511)