

Type: Hermetic piston compressors

Producer: Maneurop

Series: MTZ

Model: MTZ100

Technical data

Cylinder count:	4
Displacement [m ³ /h]:	29,8
Cylinder capacity [cm ³]:	171,3
RPM [min ⁻¹]:	2900
Weight [kg]:	60
Oil charge [dm ³]:	4
Oil type:	160PZ
Crankcase heater type:	PTC 35 W
Maximum system test pressure low side / high side:	25 / 30
Maximum number of starts without softstart [1/h]:	12
Refrigerant charge limit [dm ³]:	10
Refrigerant:	R134a, 404A/R507, R407C
Sound power [dB]:	85
Sound power with acoustic hood [dB]:	79

Connections

	<u>milimeters</u>	<u>inches</u>
Suction Rotolock valve connection:		1 3/4"
Discharge Rotolock valve connection:		1 1/4"
Suction connection with supplied sleeve:		1 1/8"
Discharge connection with supplied sleeve:		3/4"

Approvals

CCC	-
CE	+
UL	+

R134a

Cooling capacity [W]

t_c \ t_e	-15	-10	-5	0	5	10	15	20
35	6 359	8 661	11 480	14 886	18 945	23 725	29 295	35 722
40	5 697	7 884	10 560	13 795	17 655	22 208	27 523	33 667
45	5 104	7 157	9 672	12 717	16 360	20 668	25 710	31 553
50	4 585	6 487	8 823	11 660	15 067	19 112	23 863	29 386
55	4 149	5 881	8 018	10 630	13 784	17 547	21 988	27 174
60	-	5 345	7 267	9 635	12 517	15 980	20 093	24 923
65	-	-	-	8 681	11 273	14 418	18 185	22 641
70	-	-	-	-	-	12 868	16 270	20 334
75	-	-	-	-	-	-	14 357	18 010

Power input [W]

t_c \ t_e	-15	-10	-5	0	5	10	15	20
35	3 053	3 384	3 675	3 912	4 080	4 162	4 143	4 008
40	3 163	3 524	3 854	4 137	4 357	4 500	4 549	4 490
45	3 248	3 645	4 018	4 351	4 630	4 838	4 960	4 981
50	3 306	3 744	4 165	4 554	4 895	5 173	5 374	5 480
55	3 335	3 818	4 291	4 741	5 150	5 504	5 787	5 983
60	-	3 863	4 395	4 909	5 391	5 825	6 196	6 488
65	-	-	-	5 057	5 616	6 135	6 599	6 991
70	-	-	-	-	-	6 432	6 992	7 489
75	-	-	-	-	-	-	7 373	7 980

Current [A]

t_c \ t_e	-15	-10	-5	0	5	10	15	20
35	8.25	8.52	8.75	8.94	9.08	9.16	9.16	9.08
40	8.30	8.60	8.88	9.13	9.33	9.48	9.56	9.57
45	8.33	8.67	9.00	9.31	9.58	9.81	9.98	10.08
50	8.34	8.74	9.12	9.49	9.84	10.15	10.41	10.61
55	8.34	8.78	9.23	9.68	10.10	10.50	10.85	11.16
60	-	8.82	9.34	9.86	10.37	10.86	11.32	11.74
65	-	-	-	10.03	10.64	11.23	11.79	12.33
70	-	-	-	-	-	11.60	12.28	12.94
75	-	-	-	-	-	-	12.79	13.57

Mass flow [kg/s]

$t_c \setminus t_e$	-15	-10	-5	0	5	10	15	20
35	141.90	189.31	245.81	312.44	390.25	480.30	583.62	701.26
40	132.66	179.85	236.00	302.16	379.39	468.72	571.21	687.90
45	124.59	171.04	226.34	291.53	367.66	455.78	556.93	672.16
50	117.92	163.14	217.08	280.78	355.31	441.70	541.01	654.28
55	112.88	156.35	208.42	270.14	342.56	426.72	523.67	634.47
60	-	150.92	200.62	259.84	329.64	411.06	505.15	612.97
65	-	-	-	250.10	316.78	394.95	485.68	590.00
70	-	-	-	-	-	378.63	465.48	565.81
75	-	-	-	-	-	-	444.78	540.60

C.O.P. [W/W]

$t_c \setminus t_e$	-15	-10	-5	0	5	10	15	20
35	2.08	2.56	3.12	3.80	4.64	5.70	7.07	8.91
40	1.80	2.24	2.74	3.33	4.05	4.94	6.05	7.50
45	1.57	1.96	2.41	2.92	3.53	4.27	5.18	6.33
50	1.39	1.73	2.12	2.56	3.08	3.69	4.44	5.36
55	1.24	1.54	1.87	2.24	2.68	3.19	3.80	4.54
60	-	1.38	1.65	1.96	2.32	2.74	3.24	3.84
65	-	-	-	1.72	2.01	2.35	2.76	3.24
70	-	-	-	-	-	2.00	2.33	2.72
75	-	-	-	-	-	-	1.95	2.26

Operating conditions: suction superheat: 11.1 K, subcooling: 8.3 K

t_c - Condensing temperature [°C]

t_e - Evaporating temperature [°C]

Application range

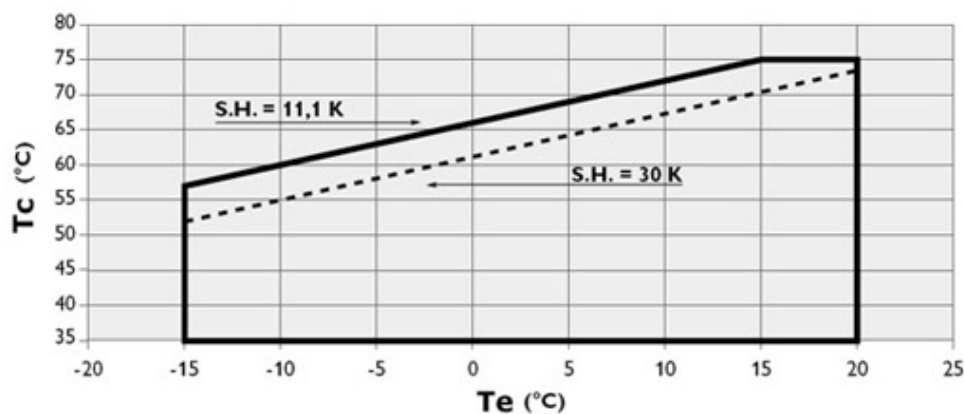

R404A/R507

Cooling capacity [W]

t_c \ t_e	-30	-25	-20	-15	-10	-5	0	5	10
30	5 175	7 247	9 826	12 976	16 759	21 239	26 480	32 545	39 497
35	4 560	6 501	8 892	11 797	15 279	19 402	24 229	29 823	36 248
40	3 917	5 730	7 937	10 602	13 787	17 556	21 973	27 101	33 003
45	3 242	4 932	6 959	9 387	12 279	15 698	19 709	24 373	29 756
50	2 532	4 102	5 953	8 148	10 751	13 824	17 432	21 638	26 505
55	-	3 238	4 916	6 883	9 200	11 931	15 140	18 891	23 246
60	-	2 336	3 846	5 587	7 622	10 015	12 829	16 129	19 976

Power input [W]

t_c \ t_e	-30	-25	-20	-15	-10	-5	0	5	10
30	3 997	4 532	5 003	5 409	5 750	6 025	6 233	6 374	6 447
35	4 062	4 676	5 223	5 704	6 117	6 461	6 736	6 942	7 077
40	4 069	4 769	5 401	5 963	6 456	6 877	7 227	7 505	7 710
45	4 008	4 802	5 526	6 178	6 758	7 265	7 697	8 055	8 338
50	3 869	4 766	5 590	6 340	7 015	7 614	8 137	8 583	8 951
55	-	4 653	5 584	6 439	7 217	7 917	8 538	9 079	9 541
60	-	4 452	5 499	6 467	7 355	8 163	8 890	9 535	10 098

Current [A]

t_c \ t_e	-30	-25	-20	-15	-10	-5	0	5	10
30	9.31	9.80	10.28	10.72	11.12	11.45	11.70	11.84	11.87
35	9.35	9.91	10.47	11.00	11.48	11.89	12.22	12.45	12.57
40	9.34	10.00	10.65	11.27	11.85	12.36	12.79	13.12	13.33
45	9.27	10.04	10.80	11.52	12.21	12.83	13.37	13.81	14.14
50	9.11	10.00	10.87	11.72	12.53	13.27	13.94	14.50	14.96
55	-	9.84	10.85	11.84	12.78	13.66	14.46	15.17	15.76
60	-	9.56	10.71	11.84	12.93	13.96	14.91	15.77	16.51

Mass flow [kg/s]

$t_c \setminus t_e$	-30	-25	-20	-15	-10	-5	0	5	10
30	162.99	222.94	294.32	378.62	477.36	592.04	724.15	875.20	1 046.69
35	154.49	214.64	285.26	367.88	463.98	575.08	702.67	848.25	1 013.33
40	143.84	204.62	274.94	356.30	450.21	558.17	681.68	822.24	981.35
45	130.29	192.14	262.59	343.14	435.30	540.56	660.43	796.41	950.00
50	113.08	176.45	247.47	327.66	418.50	521.51	638.18	770.02	918.52
55	-	156.79	228.83	309.09	399.06	500.26	614.17	742.31	886.17
60	-	132.43	205.92	286.69	376.24	476.06	587.66	712.53	852.19

C.O.P. [W/W]

$t_c \setminus t_e$	-30	-25	-20	-15	-10	-5	0	5	10
30	1.29	1.60	1.96	2.40	2.91	3.53	4.25	5.11	6.13
35	1.12	1.39	1.70	2.07	2.50	3.00	3.60	4.30	5.12
40	0.96	1.20	1.47	1.78	2.14	2.55	3.04	3.61	4.28
45	0.81	1.03	1.26	1.52	1.82	2.16	2.56	3.03	3.57
50	0.65	0.86	1.06	1.29	1.53	1.82	2.14	2.52	2.96
55	-	0.70	0.88	1.07	1.27	1.51	1.77	2.08	2.44
60	-	0.52	0.70	0.86	1.04	1.23	1.44	1.69	1.98

Operating conditions: suction superheat: 10 K, subcooling: 0 K

t_c - Condensing temperature [°C]

t_e - Evaporating temperature [°C]

Application range

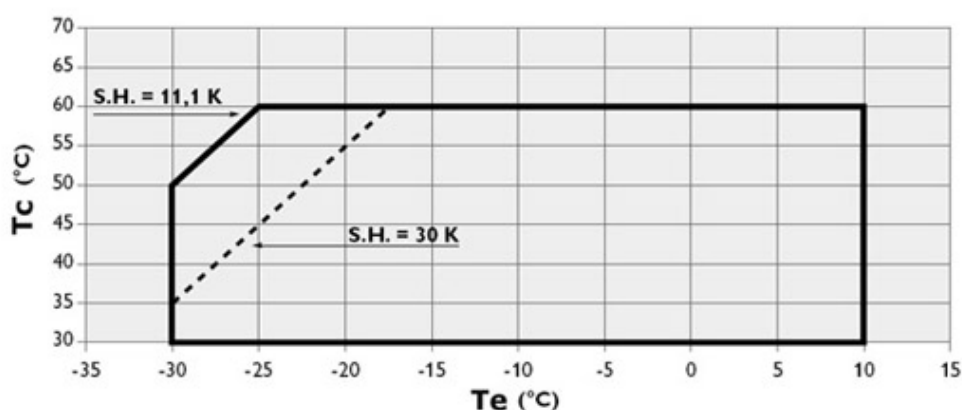

R407C

Cooling capacity [W]

t_c \ t_e	-15	-10	-5	0	5	10	15
35	9 186	12 506	16 495	21 229	26 784	33 239	40 670
40	8 185	11 303	15 045	19 488	24 708	30 783	37 790
45	7 201	10 105	13 588	17 729	22 602	28 287	34 858
50	-	8 927	12 141	15 968	20 484	25 766	31 891
55	-	-	10 720	14 221	18 368	23 237	28 904
60	-	-	-	12 506	16 273	20 717	25 915
65	-	-	-	10 839	14 213	18 221	22 940

Power input [W]

t_c \ t_e	-15	-10	-5	0	5	10	15
35	4 578	5 036	5 412	5 720	5 973	6 184	6 366
40	4 724	5 279	5 743	6 129	6 449	6 719	6 949
45	4 805	5 472	6 038	6 517	6 920	7 263	7 557
50	-	5 605	6 289	6 875	7 377	7 808	8 181
55	-	-	6 486	7 194	7 809	8 344	8 810
60	-	-	-	7 466	8 209	8 862	9 437
65	-	-	-	7 682	8 568	9 353	10 053

Current [A]

t_c \ t_e	-15	-10	-5	0	5	10	15
35	9.96	10.40	10.81	11.17	11.44	11.63	11.70
40	10.08	10.63	11.13	11.59	11.97	12.25	12.41
45	10.15	10.81	11.44	12.01	12.51	12.91	13.19
50	-	10.95	11.71	12.42	13.05	13.59	14.00
55	-	-	11.93	12.80	13.59	14.27	14.84
60	-	-	-	13.13	14.09	14.95	15.69
65	-	-	-	13.39	14.55	15.60	16.53

Mass flow [kg/s]

$t_c \setminus t_e$	-15	-10	-5	0	5	10	15
35	199.34	267.03	346.39	438.66	545.09	666.93	805.43
40	186.76	253.42	331.55	422.39	527.21	647.24	783.73
45	173.64	238.94	315.51	404.61	507.48	625.37	759.52
50	-	223.80	298.49	385.51	486.10	601.52	733.02
55	-	-	280.67	365.28	463.28	575.90	704.40
60	-	-	-	344.14	439.20	548.70	673.88
65	-	-	-	322.27	414.07	520.12	641.65

C.O.P. [W/W]

$t_c \setminus t_e$	-15	-10	-5	0	5	10	15
35	2.01	2.48	3.05	3.71	4.48	5.38	6.39
40	1.73	2.14	2.62	3.18	3.83	4.58	5.44
45	1.50	1.85	2.25	2.72	3.27	3.89	4.61
50	-	1.59	1.93	2.32	2.78	3.30	3.90
55	-	-	1.65	1.98	2.35	2.79	3.28
60	-	-	-	1.68	1.98	2.34	2.75
65	-	-	-	1.41	1.66	1.95	2.28

Operating conditions: suction superheat: 10 K, subcooling: 0 K

t_c - Condensing temperature [°C]

t_e - Evaporating temperature [°C]

Application range

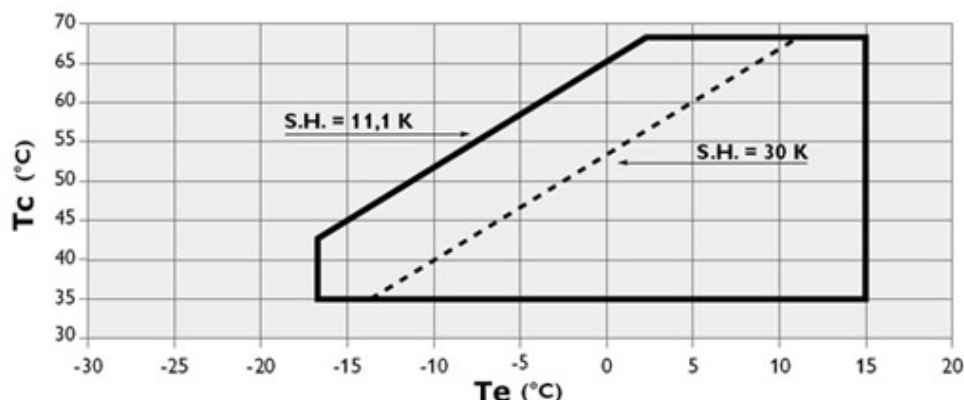

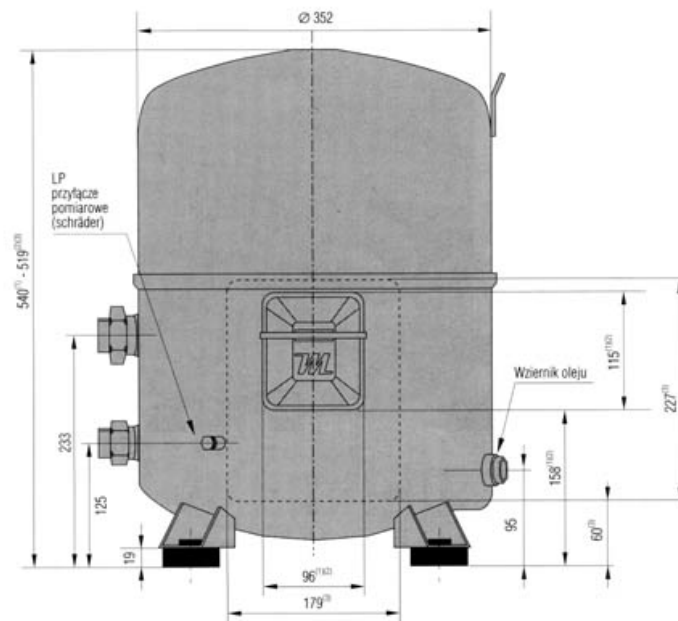
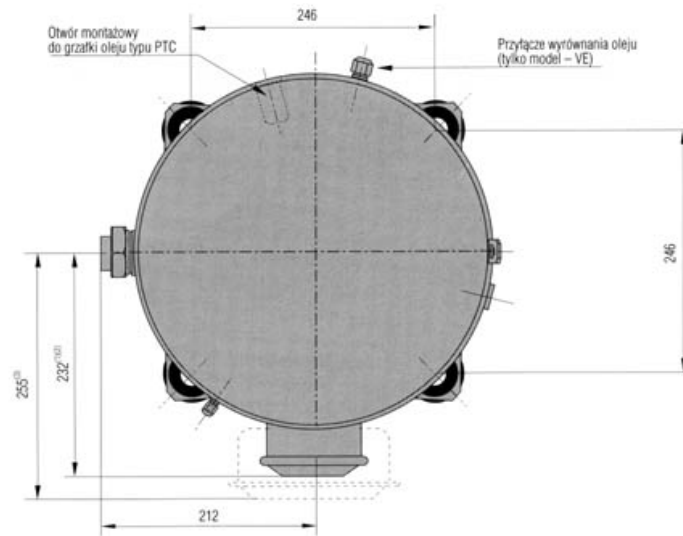



Three-phase power supply

Electrical data

Motor voltage code:	3	4	6	7	9
Starting current [A]:	157	90	126	62	110
Maximum Continuous Current (MCC) [A]:	43	22	126	17	26
Winding resistance (between phases) [Ω]:	0,5	1,57	0,67	3,1	1,26

Connection diagram for systems without refrigerant suction

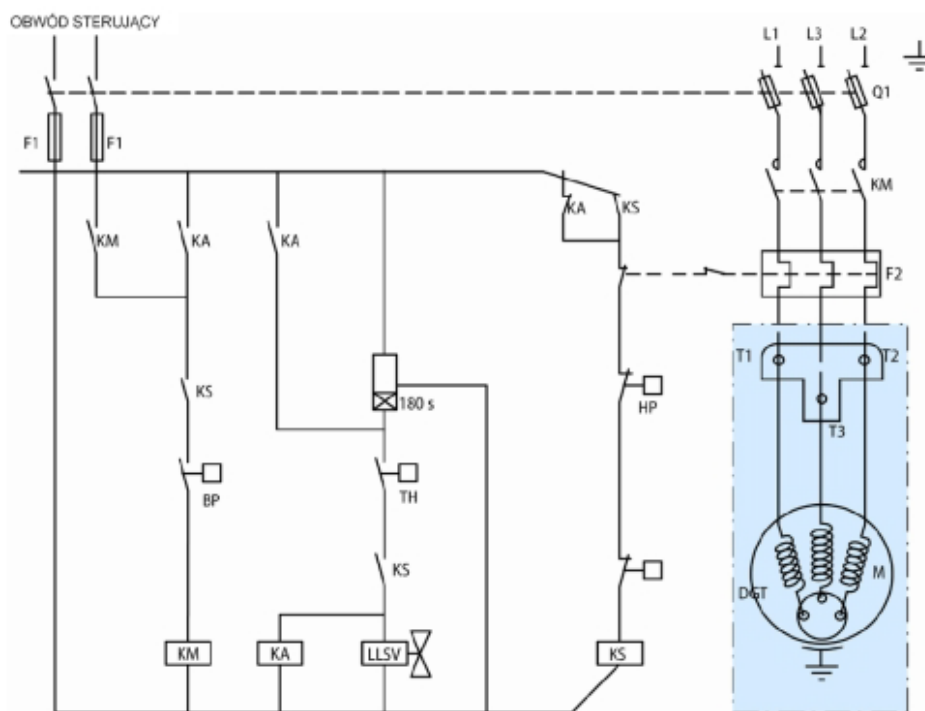

TH: Thermostat

180 s: Optional short cycle timer (3min) 5 pts

KA: Control relay

LLSV: Liquid Solenoid valve

KM: Compressor contactor

KS: Safety lock out relay

BP: Low pressure switch

HP: High pressure switch

Q1: Fused disconnect

F1: Fuses

F2: External overload protection

M: Compressor's engine

thM: Motor safety thermostat

DGT: Discharge gas thermostat

Connection diagram for systems with refrigerant suction

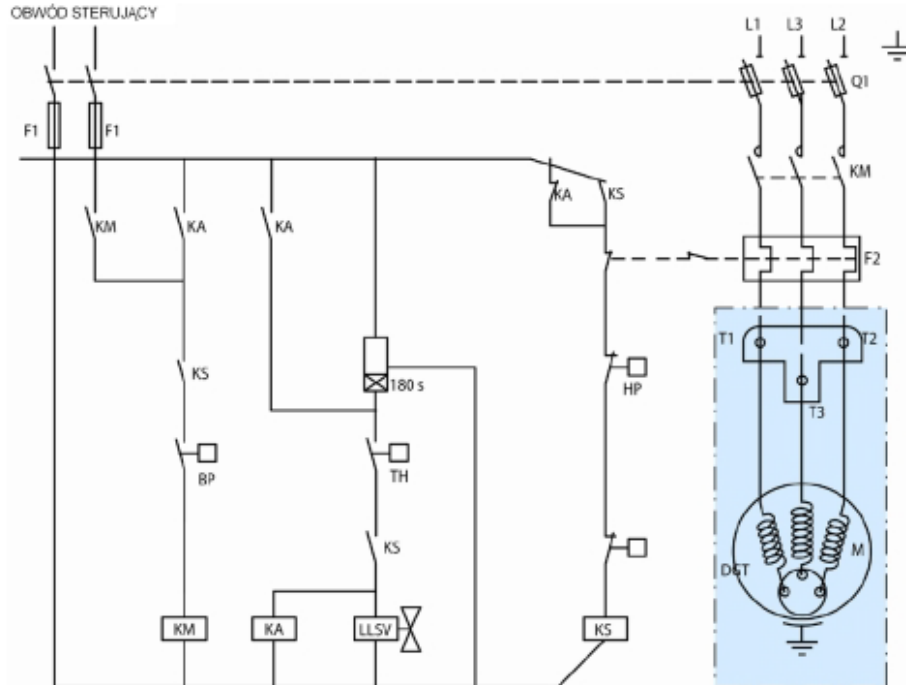

- TH: Thermostat
- 180 s: Optional short cycle timer (3min) 5 pts
- KA: Control relay
- LLSV: Liquid Solenoid valve
- KM: Compressor contactor
- KS: Safety lock out relay
- BP: Low pressure switch
- HP: High pressure switch
- Q1: Fused disconnect
- F1: Fuses
- F2: External overload protection
- M: Compressor's engine
- thM: Motor safety thermostat
- DGT: Discharge gas thermostat

Equipment

- ▶ crankcase heater - PTC 35 W
- ▶ belt type heater - crankcase heater 75W, 230V
- ▶ Rotolock valves
 - suction: Rotolock valve connection 1 3/4", connection with supplied sleeve 1 1/8"
 - discharge: Rotolock valve connection 1 1/4", connection with supplied sleeve 3/4"
- ▶ soft-start kit - electronic softstart MCI 25C
- ▶ acoustic hood - acoustic shield of Danfoss catalogue number 7755003